

Measurement of the amplitude of periodic signals using the Fibonacci method

Petrushak V.S.

*Khmelnytsky National University,
Kamyanetska str., 112/2, Khmelnytsky 29016, Ukraine*

Received 05.02.2018

Accepted for publication 25.04.2018

Abstract

Development of new methods and high-rate means for converting the amplitude of high-frequency periodic signals into a binary code with high speed for solving problems of industrial tomography, radar, radio navigation, during measurements of amplitude-frequency characteristics, measurement of the amplitude of signal generators is relevant in scientific terms and useful in practical applications. The aim of the study was to create a new amplitude meter for high-frequency periodic signals based on the Fibonacci method without converting the AC voltage into an equivalent parameter.

Based on the developed algorithm and the equation for converting the amplitude of periodic signals into code using the Fibonacci method, a functional scheme of the amplitude converter has been developed. This made it possible to realize an 8-bit amplitude converter in code on the FPGA Cyclone V series of the Altera company.

Amplitude converter of periodic signals into the code based on the Fibonacci method consists of: two comparators, a phase detector, a short pulse shaper, a digital-to-analog converter, a Fibonacci register, an extender, a clock counter, a decoder and an indicator. In the developed meters of the amplitude of the periodic signal, the process of forming the measuring periods and their calculation was applied, this made it possible to avoid the conversion of the alternating voltage into an equivalent parameter. The process of forming measurement periods and their calculation is realized on the basis of a comparator and a counter. The application of the Fibonacci register allowed setting the conversion time at the level of N/f (number of register bits / frequency of the incoming signal). Using the Fibonacci sequence of the pentanacci sequence in the basis of the work of the Fibonacci register allowed obtaining odd code values at its output.

Based on the obtained research results, a high-resolution converter of the amplitude of high-frequency periodic signals can be developed into a binary code with high speed for tasks: industrial tomography, radar and radio navigation.

Keywords: amplitude, Fibonacci method, periodic signal, digital-to-analog conversion.

DOI: 10.21122/2220-9506-2018-9-2-167-172

Адрес для переписки:

*Петрушак В.С.
Хмельницкий национальный университет,
ул. Каменецкая, 112/2, г. Хмельницкий 29016, Украина
e-mail: petrushak@ukr.net*

Address for correspondence:

*Petrushak V.S.
Khmelnytsky National University,
Kamyanetska str., 112/2, Khmelnytsky 29016, Ukraine
e-mail: petrushak@ukr.net*

Для цитирования:

*Petrushak V.S.
Measurement of the amplitude of periodic signals using the Fibonacci method.
Приборы и методы измерений.
2018. – Т. 9, № 2. – С. 167–172.
DOI: 10.21122/2220-9506-2018-9-2-167-172*

For citation:

*Petrushak V.S.
Measurement of the amplitude of periodic signals using the Fibonacci method.
Devices and Methods of Measurements.
2018, vol. 9, no. 2, pp. 167–172.
DOI: 10.21122/2220-9506-2018-9-2-167-172*

Измерение амплитуды периодических сигналов с использованием метода Фибоначчи

Петрушак В.С.

Хмельницкий национальный университет,
ул. Каменецкая, 112/2, г. Хмельницкий 29016, Украина

Поступила 05.02.2018

Принята к печати 25.04.2018

Разработка новых методов и высокоразрядных средств преобразования амплитуды высокочастотных периодических сигналов в двоичный код с высоким быстродействием для решения задач промышленной томографии, радиолокации, радионавигации, во время измерений амплитудно-частотных характеристик, измерений амплитуды генераторов сигналов является актуальным в научном отношении и полезным в практическом применении. Целью данной работы было создание нового измерителя амплитуды высокочастотных периодических сигналов на основе метода Фибоначчи без преобразования переменного напряжения в эквивалентный параметр.

На основе разработанного алгоритма и уравнения преобразования амплитуды периодических сигналов в код с использованием метода Фибоначчи разработана функциональная схема преобразователя амплитуды. Это позволило реализовать 8-разрядный преобразователь амплитуды в код на программируемой логической интегральной схеме серии *Cyclone V* фирмы *Altera*.

Преобразователь амплитуды периодических сигналов в код на основе метода Фибоначчи состоит из: двух компараторов, фазового детектора, формирователя коротких импульсов, цифро-аналогового преобразователя, регистра Фибоначчи, экстрематора, счетчика тактовых импульсов, дешифратора и индикатора. В разработанном измерителе амплитуды периодического сигнала были применены процесс формирования измерительных периодов и их подсчет, что позволило избежать преобразования переменного напряжения в эквивалентный параметр. Процесс формирования измерительных периодов и их подсчет реализованы на основе компаратора и счетчика. Применение регистра Фибоначчи позволило установить время преобразования на уровне N/f (количество разрядов регистра/частота входящего сигнала). Использование в основе работы регистра Фибоначчи последовательности пентанаиччи позволило получить нечетные значения кода на его выходе.

На основе полученных результатов исследований может быть разработан высокоразрядный преобразователь амплитуды высокочастотных периодических сигналов в двоичный код с высоким быстродействием для задач промышленной томографии, радиолокации и радионавигации.

Ключевые слова: амплитуда, метод Фибоначчи, периодический сигнал, цифро-аналоговое преобразование.

DOI: 10.21122/2220-9506-2018-9-2-167-172

Адрес для переписки:
Петрушак В.С.
Хмельницкий национальный университет,
ул. Каменецкая, 112/2, г. Хмельницкий 29016, Украина
e-mail: petrushak@ukr.net

Address for correspondence:
Petrushak V.S.
Khmelnytsky National University,
Kamyanetska str., 112/2, Khmelnytsky 29016, Ukraine
e-mail: petrushak@ukr.net

Для цитирования:
Petrushak V.S.
Measurement of the amplitude of periodic signals using the Fibonacci method.
Приборы и методы измерений.
2018. – Т. 9, № 2. – С. 167–172.
DOI: 10.21122/2220-9506-2018-9-2-167-172

For citation:
Petrushak V.S.
Measurement of the amplitude of periodic signals using the Fibonacci method.
Devices and Methods of Measurements.
2018, vol. 9, no. 2, pp. 167–172.
DOI: 10.21122/2220-9506-2018-9-2-167-172

Introduction

The theoretical basis for problems of industrial tomography [1] requires a process of measuring the amplitude of high frequency periodic signals, but not its mean root mean square or median-directed value. Since the amplitude of the reflected signal depends on the current image of the spatial distribution of physical quantities. Tracking changes in size is an urgent task for many industries. In atomic energy it can be controlled by a chain reaction in an atomic reactor. In the chemical industry, it can be controlled by the chain reaction of cracking, combustion, polymerization and other reactions. In heat power engineering it can be a control of the process of cavitation in the heat generator. This will allow for the objective control of technological processes in industrial facilities, providing technical, economic or environmental efficiency. In the radio geodesy, the area of the object of observation depends on the amplitude of the reflected signal to estimate the volume of minerals.

At the same time, the analysis of scientific and technical literature and patent search showed [2–6] that today these problems are solved by converting the alternating voltage into an equivalent constant voltage or thermal energy parameter. The use of converters based on the amplitude detector [2] results in a reduction in sensitivity, the occurrence of a conversion error, which respectively results in distortion of measurement results. In this case, the measuring channel needs to stabilize the characteristics of the transformation into the targeted efforts of scientists.

Existing means [7], which directly measure the amplitude of periodic signals, convert it into binary code and operate only at low frequencies (sigma-delta analog-to-digital converter) or have a low bit (parallel ADC) and not synchronized with the input signal. This in the first case makes it impossible to use them for research data, and in the second one, it increases the error and time of the processing of the measurement results and, accordingly, reduces the sensitivity of the receiver.

The aim of the study was to create a new amplitude meter for high-frequency periodic signals based on the Fibonacci method without converting the AC voltage into an equivalent parameter.

Main part

The essence of the developed method consists in the consistent approximation of the value of the

comparative voltage to the level of the amplitude of the input periodic signal. According to the scheme presented in Figure 1, the measurement begins with the process of comparing the amplitude value of the voltage of the input periodic signal U with the value of the comparative voltage U_c , and can be determined by the equation [8]:

$$U_{k1} = U - U_c. \quad (1)$$

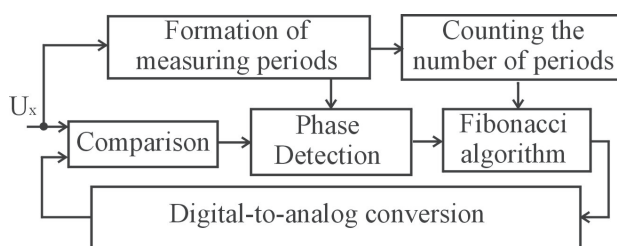

Figure 1 – Scheme of the process of measuring the amplitude of the periodic signal by Fibonacci method

Simultaneously with the comparison process, the allocation of a positive half-wave of a periodic signal occurs, that is, the formation of measuring periods. The mathematical model of such a process can be described by the expression [8]:

$$U_{k2} = (U - |U_-|)k, \quad (2)$$

where U_- – amplitude of the negative half-wave of the periodic signal; k – gain.

A mathematical model describing the process of phase detection can be set by a system of equations [9]:

$$\begin{cases} \varphi = 0, & \text{if } U \leq U_c; \\ \varphi > 0, & \text{if } U > U_c. \end{cases} \quad (3)$$

where φ – phase shift, whose value can be obtained from the expression $\varphi = 2\pi\tau_x/T$ (τ_x – time shift between the signal of the process of forming the measuring periods (U_{k2}) and the signal of the comparison process (U_{k1}), T – input signal period).

The process of the number of periods of the investigated signal can be conventionally described by the equation [10]:

$$C = 2^k,$$

where k – number of digits required to count the number of periods.

The Fibonacci sequence is defined as a series of numbers, in which each subsequent number is equal to the sum of the two previous [11]:

1, 1, 2, 3, 5, 8, 13, 21, 34, 55, 89, 144, 233, 377, 610...

The Fibonacci sequence can be conventionally described by a recurrence relation:

$$a_{n+1} = a_n + a_{n-1},$$

where $a_1 = 1, a_2 = 1$.

In theory there are tribonacci sequences, which are defined as a series of numbers, in which each subsequent number is equal to the sum of the three previous ones. Accordingly, a quaternacci and pentanacci sequence can be formed, which is defined as a series of numbers, in which each subsequent number is equal to the sum of the previous five, and this sequence of numbers can be described by the recurrence relation:

$$a_{n+1} = a_n + a_{n-1} + a_{n-2} + a_{n-3} + a_{n-4}. \quad (4)$$

The process of converting a digital code to the corresponding value of a constant voltage is characterized by a change in the value of the comparative voltage U_c by the value:

$$U_c = \frac{a_n U_0}{2^n}, \quad (5)$$

where a_n – the value of the Fibonacci number binary code; U_0 – the reference voltage required for the digital code conversion process.

Combining expressions (1)–(5) we obtain a mathematical model that describes the process of converting the amplitude of a periodic signal into a code by the Fibonacci method:

$$\left\{ \begin{array}{l} U_{k1} = U_m - U_c; \\ U_{k2} = (U_m - |U_-|) \cdot k; \\ \left\{ \begin{array}{l} \varphi = 0, \text{ if } U \leq U_c; \\ \varphi > 0, \text{ if } U > U_c; \end{array} \right. \\ a_{n+1} = a_n + a_{n-1} + a_{n-2} + a_{n-3} + a_{n-4}; \\ U_c = \frac{a_n \cdot U_0}{2^n}. \end{array} \right. \quad (6)$$

In accordance with the mathematical model (6), for the Fibonacci method, the transformation equation can be written as:

$$U_m = \left(\frac{a_{n-i} \pm \dots \pm a_n}{2^n} \right) \cdot U_0, i = \overline{k..1}. \quad (7)$$

In accordance with the mathematical model (6) and transformation equation (7), an algorithm for the process of converting the amplitude of the periodic signal into the code by the Fibonacci method is presented in Figure 2.

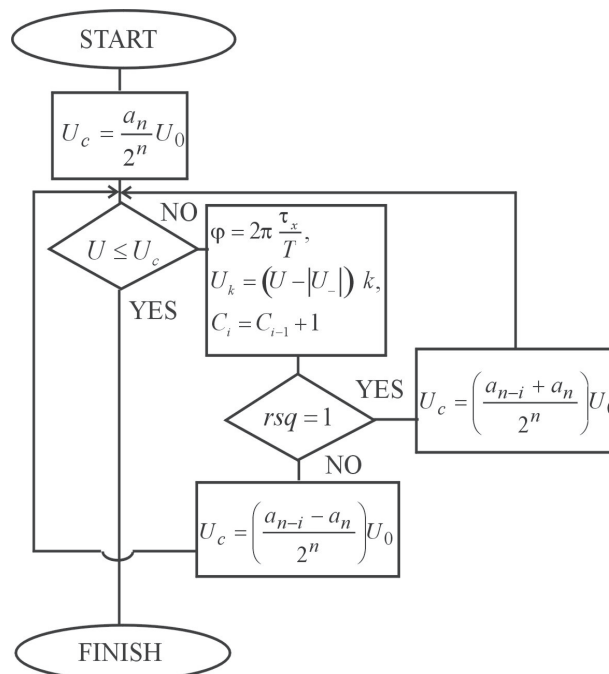

Figure 2 – Algorithm of the process of transforming the amplitude of periodic signals method of successive approximation

This algorithm displays a sequence of stages of the process of converting the amplitude of a periodic signal into a digital code, and also involves checking the condition of matching the values of the voltage of the investigated signal and the comparative voltage and checking the condition of equality of the digital equivalent of the phase shift to the value of the logical «1» or «0». Checking the first condition indicates the cyclicity of the measurement process until the moment of setting the amplitude value of the input periodic signal. Checking the second condition determines the positive or negative effect of the conversion process.

According to the mathematical model and algorithm, a functional diagram of the transformation process is developed (Figure 3) and represented by oscillograms (Figure 4), which confirm the efficiency of the developed method and obtained in the Quartus.

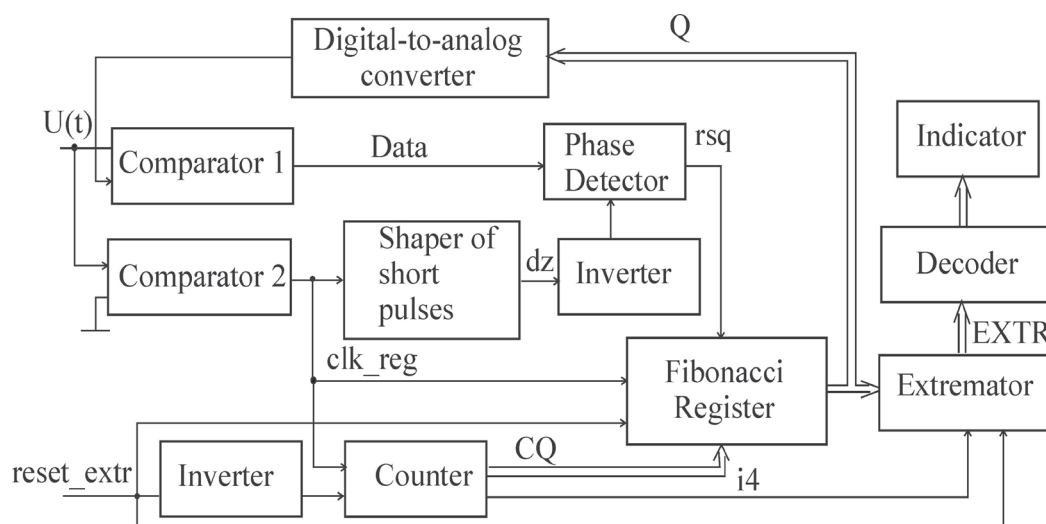

Figure 3 – Functional diagram of the converter of the amplitude of the periodic signal by Fibonacci method

The principle of the scheme is as follows.

The comparator 2 generates a sequence of rectangular pulses from the input periodic signal, which are simultaneously pulses of synchronization for the Fibonacci register, counter pulses for the counter, and a reset signal for the phase detector. The binary output code of the counter arrives at the entry of the Register data and indicates the number of the measurement period. In the case where the level of the input periodic signal applied to the positive input of the comparator 1 exceeds the value of the constant voltage applied to its negative input, a rectangular pulse will be generated at the output of the comparator. The front edge of a rectangular

pulse indicates the initial moment to form a phase interval. The end point of the phase interval is given by the front edge of the reset signal. Thus, the phase detector forms a phase interval, the presence of which during a single period of the synchronization signal sets the positive cycle of the Fibonacci register. Accordingly, the absence of a phase interval indicates a negative cycle. The binary code generated in the register sets the value of the DC voltage at the output of the digital-to-analog converter. Upon termination of the iterative process, the Fibonacci register value of the comparative constant voltage will correspond to the value of the amplitude of the input periodic signal and the measurement process will end.

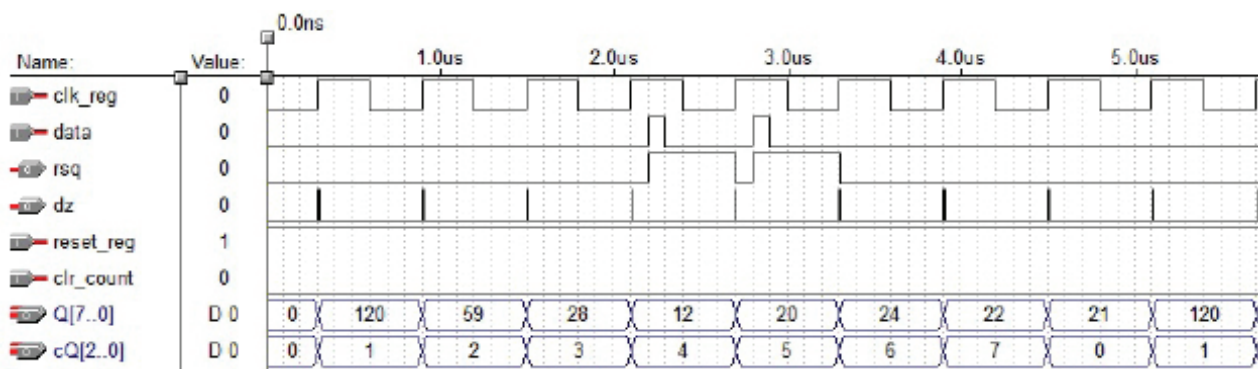

Figure 4 – Oscillograms of signals that explain the principle of the operation of the scheme

The digital part of the amplitude converter to the code by the Fibonacci method is implemented on the FPGA Cyclone V series. The Fibonacci register is implemented on the basis of

the pentanacci sequence (4), which allowed to get odd values of the code at its output. The maximum frequency of the input signal for this converter is 100 MHz.

Conclusion

The Fibonacci method for analog-to-digital conversion of the amplitude of a periodic high-frequency signal is further developed, which, unlike existing ones, consists in finding the amplitude value by increasing or decreasing the level of comparative voltage with each period of comparison, the number of which is determined by the register, which makes it possible to avoid the transformation alternating voltage to the equivalent parameter and set the conversion time and at the level N/f (number of register digits / input frequency).

The algorithm was developed and the equation for converting the amplitude of periodic signals into the code using the Fibonacci method was used, on the basis of which a functional diagram of the amplitude converter was developed. This allowed the implementation of a 8-bit amplitude converter in code on the FPGA Cyclone V series of the Altera company.

The obtained research results can be used for the development of high-frequency means of converting the amplitude of high frequency periodic signals into binary code with high speed: in industrial tomography, radar and radio navigation for the monitoring of fast-moving processes with a duration of more than 10^{-6} s.

References

1. Wang M. Industrial Tomography, Systems and Applications. Elsevier, 2015, 744 p.
2. Polischuk E.C., Dorogovets M.M., Yatsuk V.O. *Metrologiya ta vimiruvalna tekhnika* [Metrology and measuring technique]. Lviv, Beskid Bit Publ.,

2003, 544 p. (in Ukrainian).

3. Dvoryashin B.V. *Metrologiya i radioizmereniya* [Metrology and radio measurements]. Moscow, Akademiya Publ., 2005, 304 p. (in Russian).

4. Martin U. Reissland. *Electrical Measurements: Fundamentals, Concepts, Applications*. Reprinted edition. New Delhi New Age International Publishers, 2008, 340 p.

5. Doronina G.M., Lavrov V.M. *Opisaniye k patentu na izobreteniyе. G 01 R 19/04. Ustroystvo dlya opredeleniya ekstrumov elektricheskikh signalov* [Device for determining the extremes of electrical signals]; Patent UA no. 9849C1, 30.09.1999.

6. US2009/0082981 A1. Method and apparatus for measurement of amplitude of periodic signal and method and apparatus for test of magnetic head / Akifumi Muto, Kawasaki(JP). Pub. Date: Mar.26, 2009.

7. Gelman M.M. *Analog to digital converter for the informatively-measuring systems*. Publishing house of standards, 2009, 317 p.

8. Petrushak V.S., Petrushak O.M. [Simulation of the direct quantization method by level for measuring the amplitude of sinusoidal signals]. *Visnik Hmelnytskogo natsionalnogo universitetu* [Herald of Khmelnytskyi national university], 2005, vol. 2, no. 6 (in Ukrainian).

9. Trocishin I.V., Petrushak V.S., Petrushak O.M. [Development and research of the direct quantization method by level for measuring the amplitude of electrical signals]. *Vimiryuvalna tekhnika ta metrologiya* [Measuring equipment and metrology], 2006, no. 68 (in Ukrainian).

10. Opadchiy Y.F., Gludkin O.P., Gurov A.I. *Analogovaya i tsifrovaya elektronika* [Analog and digital electronics]. Moscow, Goryachaya Liniya-Telecom Publ., 2000, 768 p. (in Russian).

11. Sigler L.E. *Fibonacci's Liber Abaci: Leonardo Pisano's Book of Calculations*. New York, Springer, 2002, 638 p.